

Client _____ Quantity _____
 Project _____ Position _____

Vision NUVO Blast Chiller

Model: W6H

Cod: W64066000001



Technical data

Top:	Thickness 4 cm. Reinforced in order to place an oven
Max capacity:	8 trays GN1/1, EN60x40 h 20 mm
Gross capacity:	160 lt
Temperature range:	-40°+85°C
Refrigerant unit:	Plug-In
Yield +90 / +3:	27 Kg
Yield +90 / -18:	21 Kg
Climate class:	5
Cooling gas:	R452A
Defrost:	Hot gas
Valve:	Electronic expansion valve
Dimensions:	780x859x913 mm
Packing dimensions:	800x830x955 mm
Gross weight:	135 Kg
Voltage:	220-240 V - 50 Hz
Total rate:	1670 W
Absorbed Current:	8,07 A
Cooling capacity:	2084 W*
*:	Evap. -10°C Cond. +45°C

Features

Functions:	Blast chilling, shock freezing, thawing, proving and retarder prover, holding, desiccation, chocolate, yoghurt, steam pasteurisation, low temperature steam cooking, steam sanitizing, manual
Standard equipment:	6 slides GN1/1, EN60x40
Control:	7" touch screen display with USB port
Doors:	Cushioned, with anti-odor system
Door gasket:	Magnetic, triple chamber and easily replaceable
Core probe:	Needle probe with 1 reading point, quick-release and easily replaceable
Insulation:	60 mm thickness - CFC/HCFC free
Exterior/interior finishing:	Exterior and interior AISI 304 stainless steel. Internal and external in "linen canvas" steel
Inner corners:	Rounded for easy cleaning and ensuring maximum hygiene
Handle:	In AISI 304 stainless steel
Racks and slides:	Stainless steel AISI 304, quick release
Feets:	Stainless steel AISI 304, adjustable h 100-150 mm

COSMO - wi-fi control

Cosmo è l'innovativa tecnologia wi-fi che permette di connettere e monitorare costantemente da smartphone l'abbattitore VISION. VISION può essere anche un Cosmo hub e consentire la supervisione remota di tutti gli apparecchi Coldline a lui collegati. Dall'app Cosmo potrai controllare in tempo reale le condizioni di funzionamento di ogni macchina e ricevere alert in caso di funzionamento anomalo. Cosmo confronta costantemente le prestazioni dell'apparecchio con quelle ideali e, in caso di differenze significative, suggerisce la manutenzione necessaria. Il software VISION può ricevere gli aggiornamenti periodici rilasciati, con le più recenti funzionalità sviluppate.



Technical draw

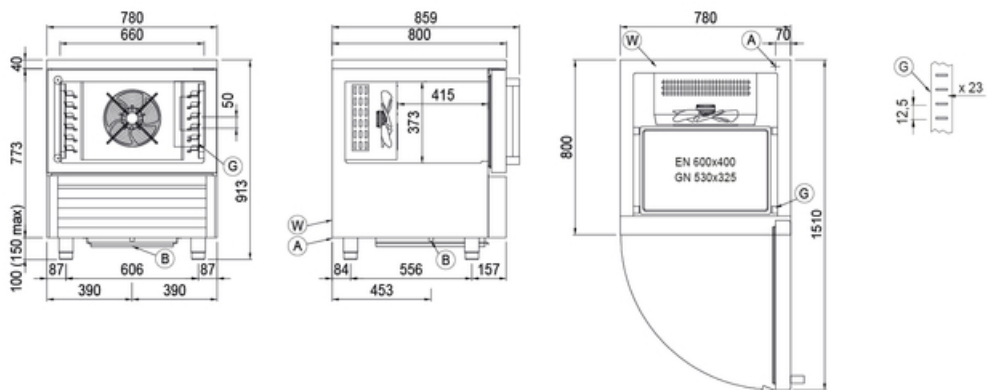

A: Power supply cable outlet
G: Racks pitch

B: Condensation water drain
W: Water mains connection - 3/4 female

In order to constantly offer the best possible products we reserve the right to make changes on technical specifications without incurring any obligation for equipment previously or subsequently sold.