



Client _____ Quantity _____
 Project _____ Position _____

Wind 550 lt cabinet EN60x40

Model: A55/1M

Cod: A24050200101

Technical data

Gross capacity:	489 lt
Temperature range:	-5°+10°C
Refrigerant unit:	Plug-In
Energetic class:	B
Energy efficiency index:	29,2
Annual consumption:	329 kW/h annum
24h consumption:	0,901 kW/h/24h
Climate class:	5
Cooling gas:	R290
Defrost:	Hot gas
Valve:	Supplied standard with solenoid
Dimensions:	630×815×2085 mm
Packing dimensions:	835×930×2250 mm
Gross weight:	130 Kg
Voltage:	220-240 V - 50 Hz
Total rate:	220 W
Absorbed Current:	1,0 A
Cooling capacity:	406 W*
*:	Evap. -10°C Cond. +55°C

Features

Standard equipment:	20 slides for EN60x40 trays, LED lighting
Control:	Electronic, display flush with the panel
Doors:	1 door, self-closing with a 105° stop, right hinged
Door gasket:	Magnetic, triple chamber and easily replaceable
Insulation:	75 mm thickness - CFC/HCFC free
Exterior/interior finishing:	Exterior and interior AISI 304 stainless steel. Back, base and internal technical compartment in galvanized/ colaminated steel.
Inner corners:	Rounded for easy cleaning and ensuring maximum hygiene
Handle:	Stainless steel AISI 304, 2 mm thick
Racks and slides:	Stainless steel AISI 304
Feets:	Stainless steel AISI 304, adjustable h 100-150 mm
Cosmo:	Ready for connection to Cosmo Hub

Accessories and variants

- Half doors
- Glass door for with led lighting
- RAL customisable colouring
- Plug-in water unit
- Power supply frequency 60Hz
- Other special voltage
- Foot pedal kit
- 4 Swivel and brake castors h 128 mm
- Aluminium coated backing-pan EN60x40 h 20 mm
- Plastic coated shelf EN60x40
- Pair of type L slides 605 mm
- Serial interface, RS485 cable
- Cosmo connection kit

COSMO - wi-fi control

Cosmo is the wi-fi technology that allow to connect and monitor all Coldline appliances. Connect Windcabinets to a Cosmo hub (MODI, VISION or LEVTRONIC) and from the app you can check the operating conditions of each machine and receive alerts in case of abnormal functioning.

*The installation requires a kit for the replacement of the racks

Technical draw

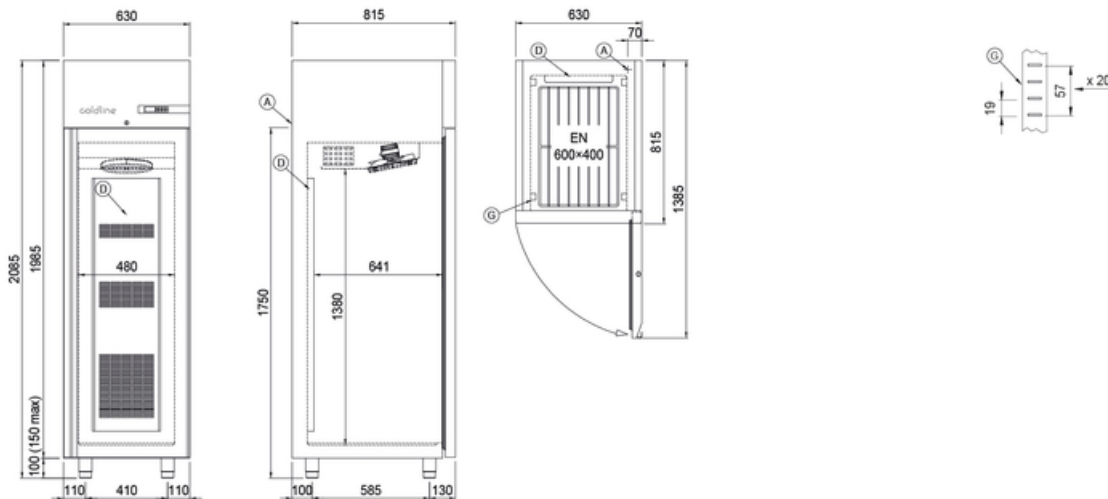

A: Power supply cable outlet

D: Airflow conveyor

G: Racks pitch