

Client _____ Quantity _____
 Project _____ Position _____

Levtronic EN60x40 counter 3 doors

Model: TP17/1FH-660

Cod: T30301000803



Technical data

Top:	With top and splashback
Max capacity:	21 trays EN60x40
Gross capacity:	557 lt
Temperature range:	-6°+40°C
Ventilation range:	25% - 100%
Humidity range:	45% - 95% with humidifier
Humidifier:	Incluso
Refrigerant unit:	Plug-In
Climate class:	5
Cooling gas:	R452A
Defrost:	Hot gas
Body height:	660 mm
Valve:	Supplied standard with solenoid
Dimensions:	2005×800×800 mm
Packing dimensions:	2100×900×990 mm
Gross weight:	166 Kg
Voltage:	220-240 V - 50 Hz
Total rate:	1500 W
Absorbed Current:	6,9 A
Cooling capacity:	565 W*
*:	Evap. -10°C Cond. +55°C

Features

Functions:	Retarder prover, manual proving, continuous cycle and storage
Standard equipment:	12 slides EN60x40
Control:	4,3" touch screen display with USB port
Doors:	3 doors, self-closing, reversible with 105° stop
Door gasket:	Magnetic, triple chamber and easily replaceable
Insulation:	60 mm thickness - CFC/HCFC free
Exterior/interior finishing:	Exterior interior and back in AISI 304 stainless steel. Base in colaminated steel
Inner corners:	Rounded for easy cleaning and ensuring maximum hygiene
Handle:	Stainless steel AISI 304, 2 mm thick
Racks and slides:	Stainless steel AISI 304
Feets:	Stainless steel AISI 304, adjustable h 100-150 mm
Cosmo:	Wi-Fi remote control system

Accessories and variants

RAL customisable colouring
Stainless steel evaporator
Power supply frequency 60Hz
Other special voltage
Purity C Quell ST 50 filter cartridge
Aluminium coated backing-pan EN60x40 h 20 mm
Stainless steel shelf EN60x40
Plastic coated shelf EN60x40
Pair of type L slides 605 mm
Serial interface, RS485 cable
IP44 schuko socket with cover
Removable plinth EN 3D h 50 mm
Removable plinth EN 3D h 100 mm
Removable plinth EN 4D h 150 mm

COSMO - wi-fi control

Cosmo is the wi-fi technology that allow to connect, update and monitor with a smartphone the LEVTRONIC retarder prover devices. VISION is also a Cosmo hub and allow remote supervision of the Coldline devices connected to it. From the app you can check the operating conditions of each machine and receive alerts in the event of abnormal operation.

*The installation requires a kit for the replacement of the racks

Technical draw

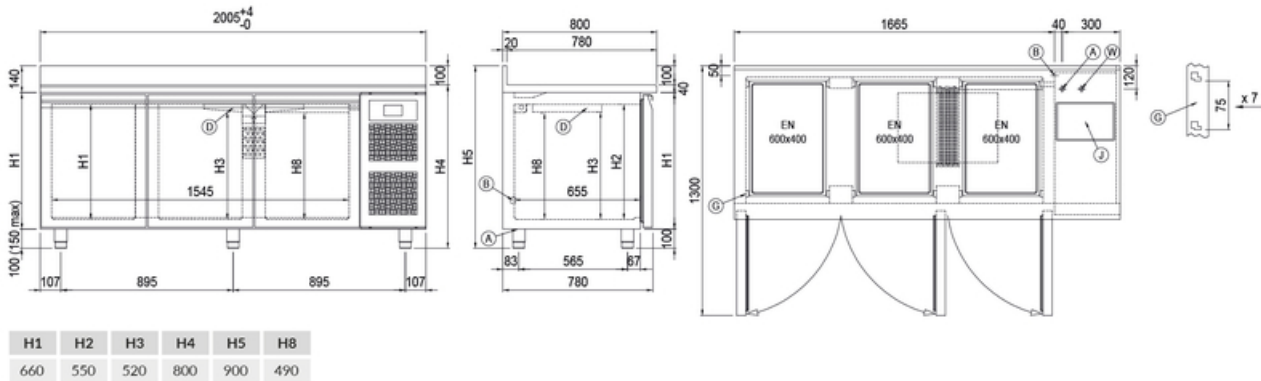

A: Power supply cable outlet

B: Condensation water drain

D: Airflow conveyor

G: Racks pitch

J: Automatic evaporation of condensing water

W: Water mains connection for humidifier - 3/4" female. Unloading not required