



Blast chiller built-in LIFE W45 White Ice Inox

Model: W45BX-CL
Code: W710540000

Functions

Blast chilling, blast freezing, proving, defrosting, storage, chocolate, yoghurt, bottle chilling

Operating modes

Standard programs, with core temperature probe, without core temperature probe

Standard fittings

2 racks 448 x 325 x 32 mm,
core temperature probe, sanitizer

Temperatures

-40°C / +45°C

Capacity

26 litres, 3 trays

Interior measurements

455 x 349,5 x 178mm

Cooling capacity

900W [Evap - 10°C cond. +40°C]

Exterior finish

Glass, Scotch Brite

Fan speed

Adjustable from 25% - 100%

Weight

55 kg

Exterior measurements

595 x 575 x 462 mm

Power supply

220V-240V / 50Hz

Interior finish

AISI 304 stainless steel
scratch-resistant



Display

Touch screen, 4.3 inches

Refrigerant gas

R 290, GWP 3,3

Packaging measurements

620 x 680 x 590 mm

Maximum power demand

540 W - 2.8A

Door hinge

Bottom, lift-up door

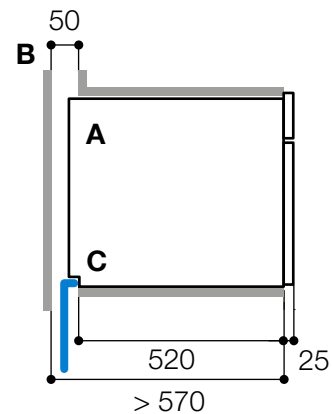
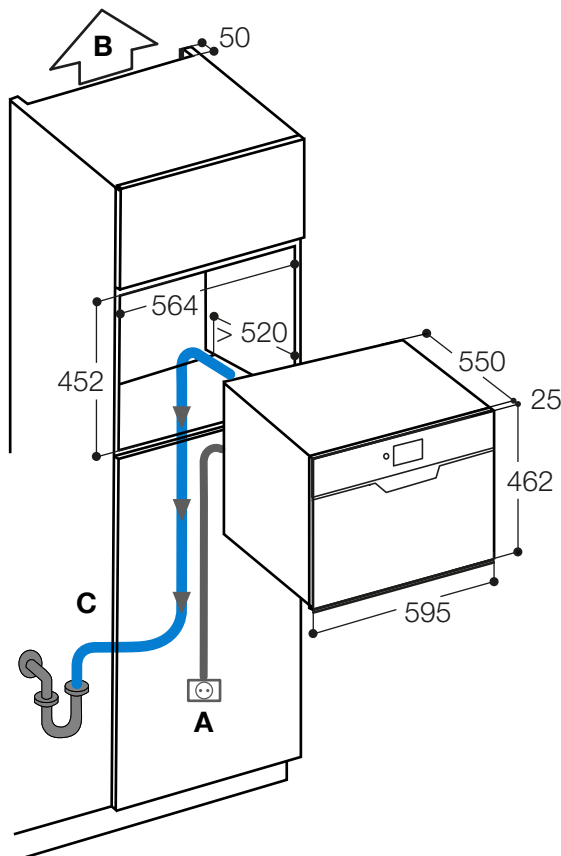

A: 3.40 m-long power cord with Schuko plug.

B: To recirculate air, you will need ducting measuring at least 50 mm in the upper part of the cavity due to house the unit.

C: The unit will need to be connected to the drain.

To order version without drain please add "-DF" after the code of the model you need (example: W60N-CL-DF).