

Client \_\_\_\_\_ Quantity \_\_\_\_\_  
 Project \_\_\_\_\_ Position \_\_\_\_\_

## Vision F Blast Chiller

**Model:** W7F

**Cod:** W64073000001



### Technical data

|                            |  |
|----------------------------|--|
| <b>Top:</b>                | Thickness 4 cm. Reinforced in order to place an oven |
| <b>Max capacity:</b>       | 11 trays GN1/1, EN60x40 h 20 mm                      |
| <b>Gross capacity:</b>     | 238 lt   |
| <b>Temperature range:</b>  | -40°+65°C  |
| <b>Refrigerant unit:</b>   | Plug-In  |
| <b>Yield +90 / +3:</b>     | 34 Kg  |
| <b>Yield +90 / -18:</b>    | 24 Kg  |
| <b>Climate class:</b>      | 5  |
| <b>Cooling gas:</b>        | R452A  |
| <b>Defrost:</b>            | Hot gas  |
| <b>Valve:</b>              | Electronic expansion valve                           |
| <b>Dimensions:</b>         | 780x859x1093 mm                                      |
| <b>Packing dimensions:</b> | 800x830x1135 mm                                      |
| <b>Gross weight:</b>       | 145 Kg   |
| <b>Voltage:</b>            | 220-240 V - 50 Hz                                    |
| <b>Total rate:</b>         | 1950 W   |
| <b>Absorbed Current:</b>   | 9,42 A   |
| <b>Cooling capacity:</b>   | 2084 W*  |
| <b>*:</b>                  | Evap. -10°C Cond. +45°C                              |

### Features

|                                     |  |
|-------------------------------------|--|
| <b>Functions:</b>                   | Blast chilling, shock freezing, thawing, proving and retarder prover, holding, desiccation, chocolate, yoghurt, steam sanitizing, manual cycle |
| <b>Standard equipment:</b>          | 7 slides GN1/1, EN60x40  |
| <b>Control:</b>                     | 7" touch screen display with USB port  |
| <b>Doors:</b>                       | Cushioned, with anti-odor system   |
| <b>Door gasket:</b>                 | Magnetic, triple chamber and easily replaceable  |
| <b>Core probe:</b>                  | Needle probe with 1 reading point, quick-release and easily replaceable  |
| <b>Insulation:</b>                  | 60 mm thickness - CFC/HCFC free  |
| <b>Exterior/interior finishing:</b> | Exterior and interior AISI 304 stainless steel. Internal and external in "linen canvas" steel  |
| <b>Inner corners:</b>               | Rounded for easy cleaning and ensuring maximum hygiene   |
| <b>Handle:</b>                      | In AISI 304 stainless steel  |
| <b>Racks and slides:</b>            | Stainless steel AISI 304, quick release  |
| <b>Feets:</b>                       | Stainless steel AISI 304, adjustable h 100-150 mm  |

**COSMO - wi-fi control**

Cosmo is the innovative wi-fi technology that allows you to constantly connect and monitor from your smartphone the VISION blast chiller. VISION can also be a Cosmo hub and allow remote supervision of all Coldline devices connected to it. From the Cosmo app you can check the operating conditions of each machine in real time and receive alerts in the event of abnormal operation. Cosmo constantly compares the performance of the device with the ideal ones and, in case of significant differences, suggests the necessary maintenance. The VISION software can receive periodic updates released, with the latest features developed.



**Technical draw**

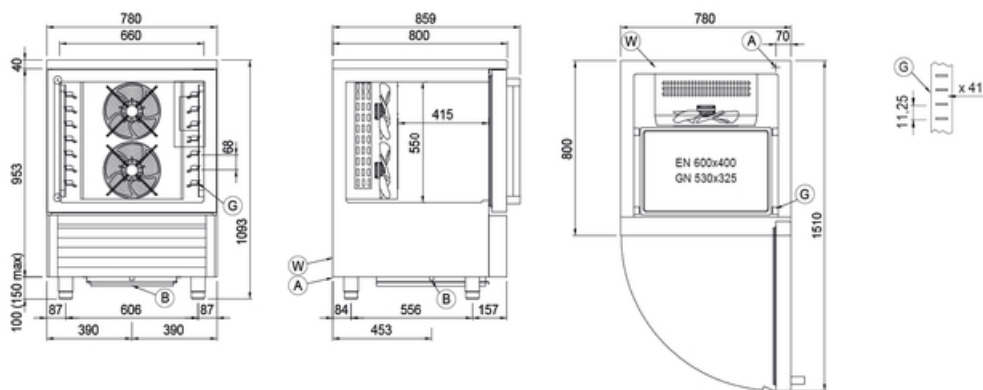

- A:** Power supply cable outlet
- G:** Racks pitch

- B:** Condensation water drain
- W:** Water mains connection - 3/4 female

In order to constantly offer the best possible products we reserve the right to make changes on technical specifications without incurring any obligation for equipment previously or subsequently sold.