

Client _____ Quantity _____
 Project _____ Position _____



Vision F Power Blast Chiller

Model: W20PF

Cod: W68103100001

Technical data

Top:	4 cm thickness
Max capacity:	20 trays GN2/1, EN60x80 h 20 mm
Gross capacity:	513 lt
Temperature range:	-40°+65°C
Refrigerant unit:	Plug-In
Yield +90 / +3:	80 Kg
Yield +90 / -18:	60 Kg
Climate class:	5
Cooling gas:	R452A
Defrost:	Hot gas
Valve:	Electronic expansion valve
Dimensions:	1100×1104×1843 mm
Packing dimensions:	1140×1140×1860 mm
Gross weight:	220 Kg
Voltage:	400-415 V - 50-60 Hz
Total rate:	7150 W
Absorbed Current:	16,64 A
Cooling capacity:	9820 W*
*:	Evap. -10°C Cond. +45°C

Features

Functions:	Blast chilling, shock freezing, thawing, proving and retarder prover, holding, desiccation, chocolate, yoghurt, steam sanitizing, manual cycle
Standard equipment:	10 slides GN2/1, EN60x80
Control:	7" touch screen display with USB port
Doors:	Cushioned, with anti-odor system
Door gasket:	Magnetic, triple chamber and easily replaceable
Core probe:	Needle probe with 1 reading point, quick-release and easily replaceable
Insulation:	60 mm thickness - CFC/HCFC free
Exterior/interior finishing:	Exterior and interior AISI 304 stainless steel. Internal and external in "linen canvas" steel
Inner corners:	Rounded for easy cleaning and ensuring maximum hygiene
Handle:	In AISI 304 stainless steel
Racks and slides:	Stainless steel AISI 304, quick release
Feets:	Stainless steel AISI 304, adjustable h 100-150 mm

COSMO - wi-fi control

Cosmo is the innovative wi-fi technology that allows you to constantly connect and monitor from your smartphone the VISION blast chiller. VISION can also be a Cosmo hub and allow remote supervision of all Coldline devices connected to it. From the Cosmo app you can check the operating conditions of each machine in real time and receive alerts in the event of abnormal operation. Cosmo constantly compares the performance of the device with the ideal ones and, in case of significant differences, suggests the necessary maintenance. The VISION software can receive periodic updates released, with the latest features developed.



Technical draw

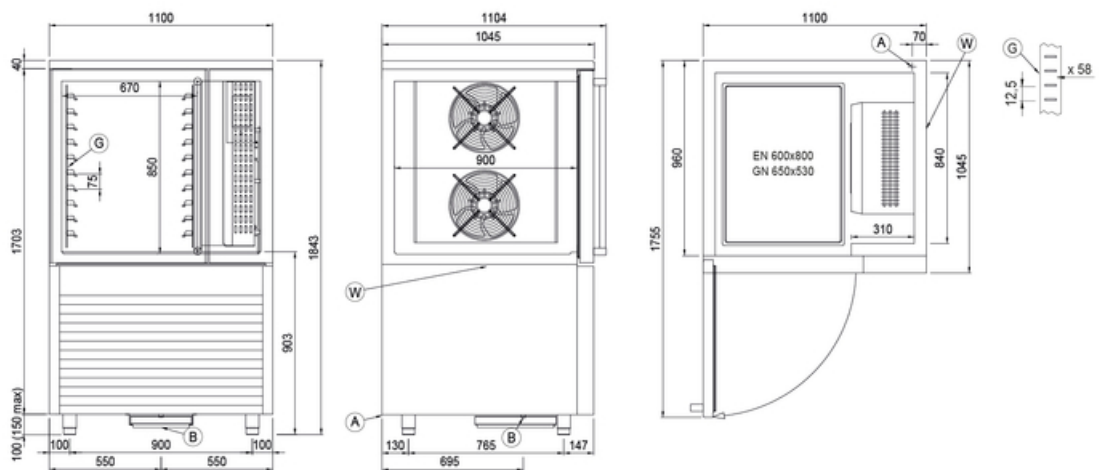

- A:** Power supply cable outlet
- G:** Racks pitch

- B:** Condensation water drain
- W:** Water mains connection - 3/4 female

In order to constantly offer the best possible products we reserve the right to make changes on technical specifications without incurring any obligation for equipment previously or subsequently sold.