

Mychef Bakershop 4 600x400



TECHNICAL SPECIFICATIONS

Capacity	4 x 600x400
Distance between guides	75 mm
Rations per day	120-360
Maximum temperature	260 °C
Dimensions (WxDxH)	760x760x522
Weight	58 Kg
Packaging dimensions (WxDxH)	900x830x1070
Gross weight	74 Kg
Power	6,3 kW
Voltage	400/3L+N/50-60
Water	R 3/4"
Drainage	No drainage
Water pressure	150 - 400 kPa

GENERAL SPECIFICATIONS

- LCD control panel
- Regulation of humidity, temperature, time and speed
- 40 programs with 3 cooking phases each
- 8 quick access memories
- Convection cooking with humidity contribution from 30°C to 260°C
- High thermal inertia camera
- Fan stop when door is opened
- Two fan speeds and reverse rotation
- LED camera illumination
- Low emission double glass hinged door
- Door opening positioner
- EN Guides
- Door and frame rainwater collection system with drainage

OPTIONALS

- Door opening on the left hand side
- Water connection kit to carafe
- Connection 230V/L+N/50-60
- Connection 230V/3L/50-60

ACCESSORIES

- Special trays for each baking
- Washing shower
- Condensation hood
- Detergent DA21
- Support table
- Wall bracket
- WiFi connection
- MyCloud remote control
- Compatible with Google Home Voice Control

INSTALLATION DETAILS

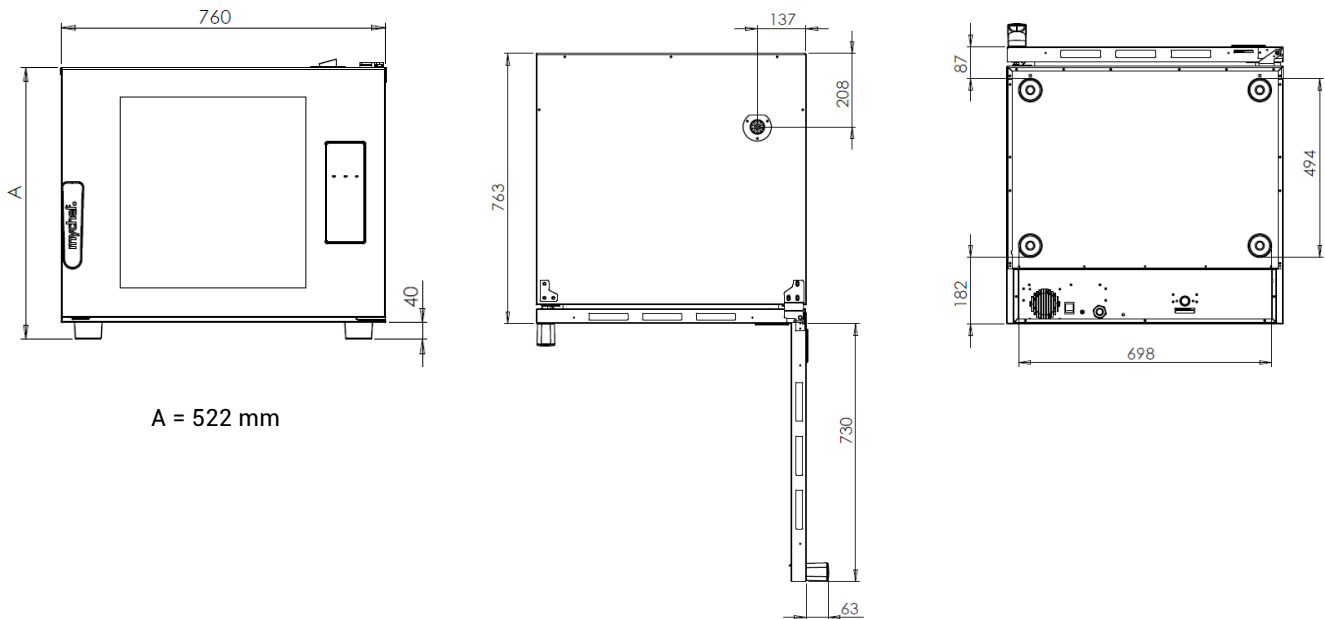

A = 522 mm

SAFETY DISTANCES

- Sides = 50 mm
- Rear = 100 mm
- Upper = 500 mm
- Heat sources = 1000 mm
- It must be completely level

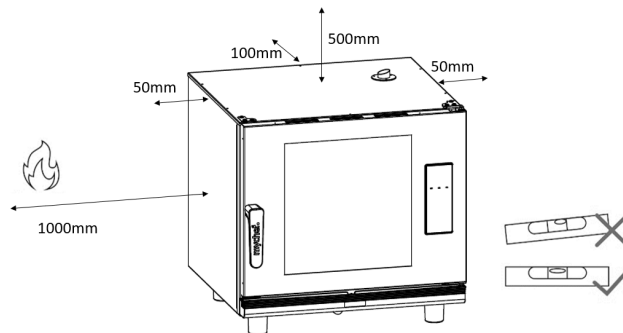

POWER CONNECTION

	Power (kW)	Current (A)
400/3L+N/50-60	6,3	14,2
230/L+N/50-60 (optional)	6,3	27,4

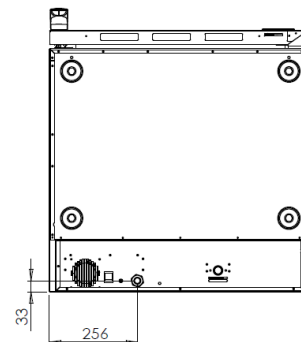

WATER CONNECTION

A Connection 3/4" treated water

QUALITY OF WATER

- Temperature < 30°C
- Pressure 150 to 400 kPa dynamic flow
- Hardness between 3° and 6° FH
- PH between 6.5 and 8.5
- Chlorides below 30 ppm
- Use of water softener and filter required

